



# ULTRA SPOT

## LCG-MHS150L / SPOT 150 LED

### Technical data

#### FEATURES

LED Type: 150W white LED  
 Beam Angle: 16°  
 Motorized focus (2.5M-30M)  
 3-Facet prism with variable speed & direction  
 Preset variable / random strobe & dimming pulse effect  
 25T/sec high speed LED shutter/strobe effect with variable speed

#### Movement

Smooth & precise resolution for PAN/TILT  
 360° / 540° / 630° PAN & 90°/180°/270° TILT  
 Scan position memory, auto reposition after unexpected movement

#### Control

Control signal: DMX512, Master/Slave, Sound activated, Auto (7 built-in programs)  
 Control Channel: 14CH / 12CH USITT DMX-512  
 Display: Illuminated graphic LCD

#### Colors

1 Color wheel with 8 colors plus open

#### GOBOS

1 Rotating Gobo Wheel with 6 gobos plus open  
 1 Static Gobo Wheel with 10 gobos plus open

#### Connectors

Signal connection: XLR 3-Pin In/Out  
 Power Input: PowerCON IN/OUT

#### Operating Conditions

Input voltage: 90-260V AC / 50-60Hz  
 Power: 195W  
 Maximum ambient temperature: -30°C / 86°F, 50°C / 122°F  
 IP20 protection rating

#### Mounting Options

Standing: Rubber feet  
 Hanging: 1x 1/4 turn fastening Omega clamp  
 Safety wire attachment: foldout eyelets

#### Shipping

Single fixture:

#### Housing Colors

ABS die-cast plastic cover with Aluminium structure  
 Standard colors: black

#### Dimensions

Length: 266 mm / 10.5 in  
 Width: 177 mm / 7.0 in  
 Height (head horizontal): 362 mm / 14.3in

**Weight** N.W: 6.8kgs / N.W: 13 lbs



### Dimension

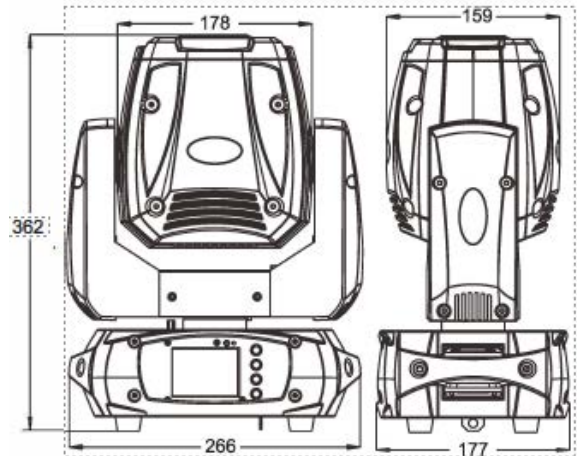

### Photometrics

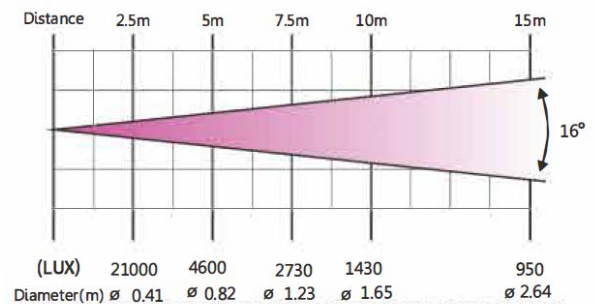

L.C GROUP | 422, Chemin des Prairies, Joliette, Québec, Canada, J6E 4J8  
 Tel: (450) 755-6091 | Toll free: (800) 263-6091  
 www.lc-group.ca | info@lc-group.ca