



STORM 1000

LCG-6480 / LED STROBE WASH IP65

Technical data

Strobe Panel LEDs

LED Type: 5050 0.5W RGB 3in1 LEDs
 LED Count: 480
 LED Colors: RGB
 LED Segments: 8 (2 x 4)

Strobe Tube LEDs

LED Type: 3535 5W 6500K LEDs
 LED Count: 144
 LED Colors: Cool-White
 LED Segments: 4

Movement

Resolution: 8-16 Bit
 Tilt (Degrees): 185°

Control

Control Modes: 7CH / 14CH / 16CH / 42CH / 44CH
 Display: Illuminated graphic LCD
 Protocol: USITT DMX-512, RDM
 RDM: Bidirectional communication
 Wireless DMX: 2.4 GHz W-DMX™ (optional)
 Cooling: Temperature controlled, overheating protection

Effects

Dimmer: 0-100% electronic
 Shutter: electronic, max. 20 Hz
 Internal Effects: LED Macro Effects

Connectors

Signal connection: Seetronic IP65 XLR 5-Pin or 3-Pin In/Out
 Power Input: Seetronic powerCON TRUE1 In/Out

Operating Conditions

Mains voltage: 100-240V AC / 50-60Hz
 Power: 1000W
 Maximum ambient temperature: -30°C / 86°F, 50°C / 122°F
 Operating Position: any

Mounting Options

Hanging: Omega-Bracket
 Safety wire attachment: foldout eyelets

Shipping

Single fixture: cardboard (inner and outer cartons)
 Tourpack: 4-way Flight Case

Housing Colors

Standard colors: black



Dimension

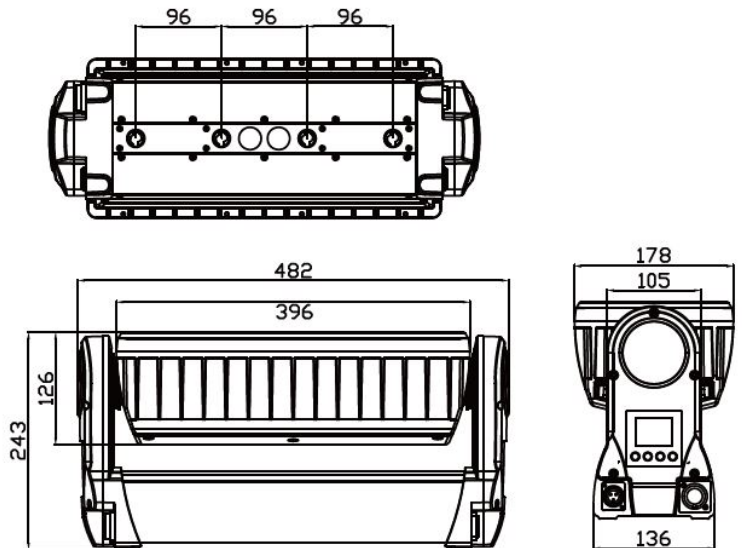

Dimensions

Length: 482 mm / 18.9 in
 Width: 178 mm / 9.0 in
 Height (head horizontal): 243 mm / 9.5 in

Weight

N.W: 10 kg / G.W: 12.5 kg



L.C GROUP | 422, Chemin des Prairies, Joliette, Québec, Canada, J6E 4J8
 Tel: (450) 755-6091 | Toll free: (800) 263-6091
 www.lc-group.ca | info@lc-group.ca